



LRU/HIL Test Systems



An Agile Approach to LRU and Control
Unit Hardware-in-the-Loop Testing

ni.com



Explore NI's Solutions

Aerospace and defense companies face soaring development costs and complexities due to many factors including the complicated embedded software, electronics, systems, and integration challenges required in manned/unmanned aircraft, space launch vehicles, and new urban air mobility approaches. At the same time, the pressure to develop products and systems faster and at a lower cost continues to rise. Dated test approaches and equipment exacerbate problems, making adaptability to changing requirements and early product testing difficult.

- 03 SOLUTION OVERVIEW
- 04 LRU HIL TEST SYSTEMS OVERVIEW
- 06 LRU TEST SYSTEMS: SOLUTION DELIVERY FORMATS
- 13 SYSTEMS-ON-DEMAND FROM SET GMBH
- 16 SYSTEMS-ON-DEMAND FROM TECH180
- 19 NI LRU TEST SYSTEM (LRUTS) REFERENCE ARCHITECTURE
- 21 LRU HIL RUN-TIME SYSTEM-LEVEL ARCHITECTURE
- 22 LRU HIL SYSTEM SOFTWARE
- 25 LRU HIL SYSTEM HARDWARE COMPONENTS AND I/O
- 30 SERVICES AND SUPPORT
- 31 LRUTS REFERENCE ARCHITECTURE PARTNER ECOSYSTEM



Conventional approaches for aerospace and defense test are badly outdated and in need of disruption. Engineers and enterprises are looking for new ways to leverage test as a competitive advantage, using it to reduce costs and accelerate product introductions while maintaining agility and equipment utilization. We are confident that NI's collaboration with SET and Tech180 will deliver the right approach and system-level capability necessary for our customers to meet test requirements at an accelerated rate.

Luke Schreier
VP and GM Aerospace, Defense, and Government, NI



Solution Overview

At NI, we continue to develop COTS hardware and software to address the underlying needs of testing complex products and systems. Customers have relied on NI platforms such as PXI for years when designing and building their own test systems, whether it's part of an automatic test system (ATS) for a sixth-generation fighter aircraft or electronic ground support equipment (EGSE) for the next small space-launch vehicle. And a few years ago, with our curated ecosystem, we codeveloped the Switch Load and Signal Conditioning (SLSC) platform, a COTS-based solution that provides greatly improved connectivity with standardized cabling, connectors, and pinouts. This platform adds a new type of COTS-based modularity and standardization that simplifies the implementation of the complex cabling and wiring required for these types of validation systems.

Our curated partners further extend our breadth of solutions, providing capabilities in designing, building, and supporting HIL test systems for controllers, whether line-replaceable units (LRUs), packages, or just onboard computing systems. Together, we can help improve your approach to your LRU testing needs, from incorporating more COTS-based hardware and software in highly customized systems from Bloomy, to achieving new types of business-level impacts using the innovative Systems on Demand from NI's strategic collaboration with SET GmbH and Tech180.

LRU HIL Test Systems Overview

HIL test systems comprise a series of different modular, COTS-based hardware and software components. These components are similar across different size test systems.

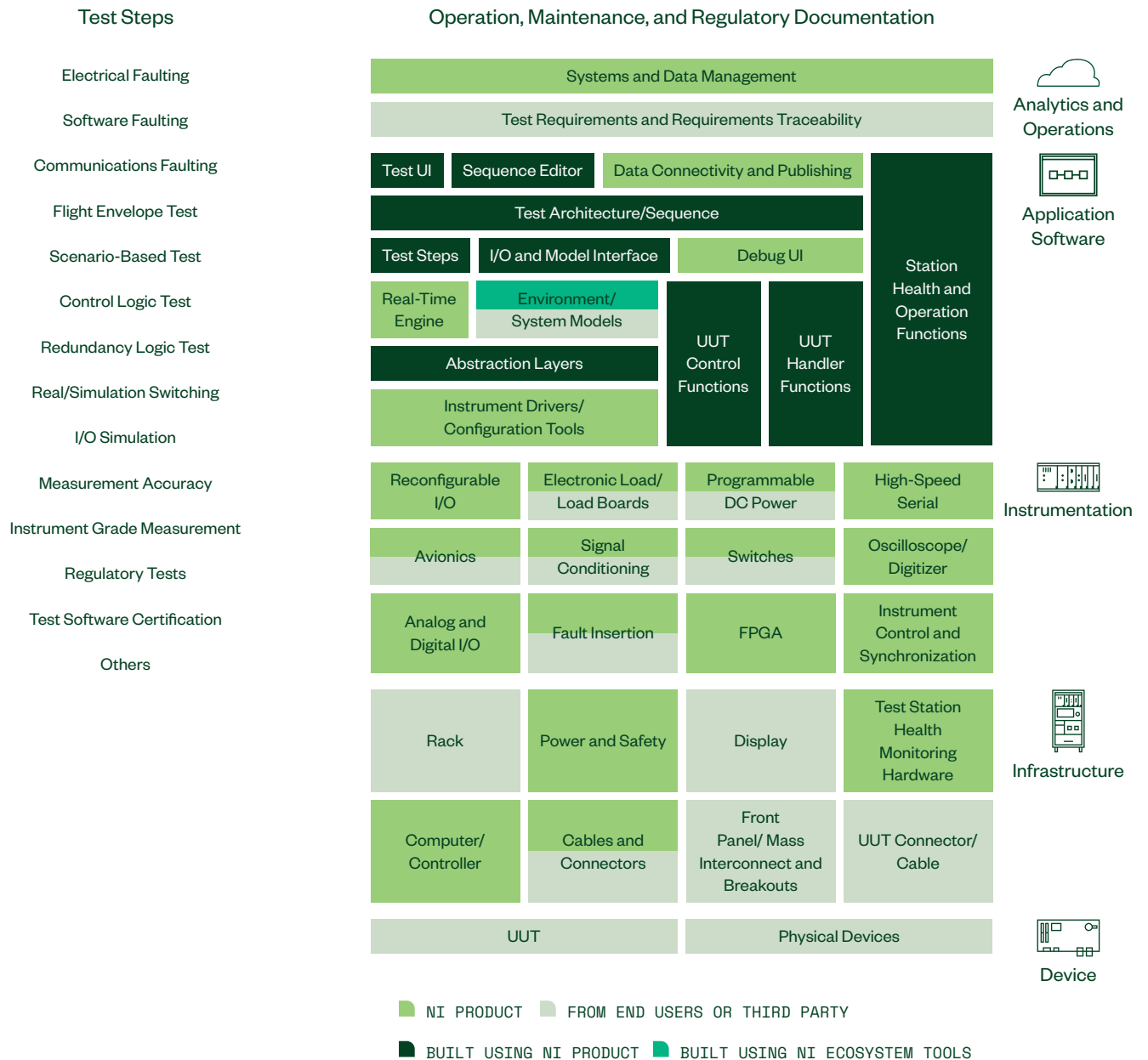

FIGURE 01

Key Hardware and Software Components of a Hardware-in-the-Loop Test System

By building on this base of components, a variety of systems can be constructed, from smaller HIL systems at the desktop level to large, multi-42U and beyond rack systems to test at the full systems integration-lab level.

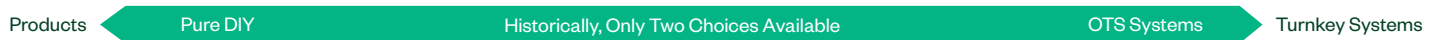

FIGURE 02

Test Systems that Scale to Requirements Based on a Modular Approach Backed by NI Hardware and Software

LRU Test Systems: Solution Delivery Formats

Historically, there have been two choices available to test complex LRU software: design, build, and integrate systems in-house, or acquire turnkey systems that are built or modified to meet requirements and specifications.



A long-time challenge has been meeting a variety of often-competing goals when internal and market constraints exist. Goals—or rather desired outcomes—can normally be categorized into some versions of the following list. One may have all or a subset of these as desired outcomes:

- Open and customizable
- Readily reconfigurable, test asset reuse
- Sustainment, obsolescence, version management
- Consistent user experience, training, support, documentation
- Decrease NRE
- Decrease CapEx
- Decrease total cost of test
- Decrease tester build schedule
- Decrease time to market

Additionally, while pursuing these goals, risk is often one of the most important decision criteria. Increasing risk is usually something that will determine what is and is not going to be done. As shown in Figure 3, having two historical choices with little overlap in value limits the likelihood of you achieving your desired outcomes.

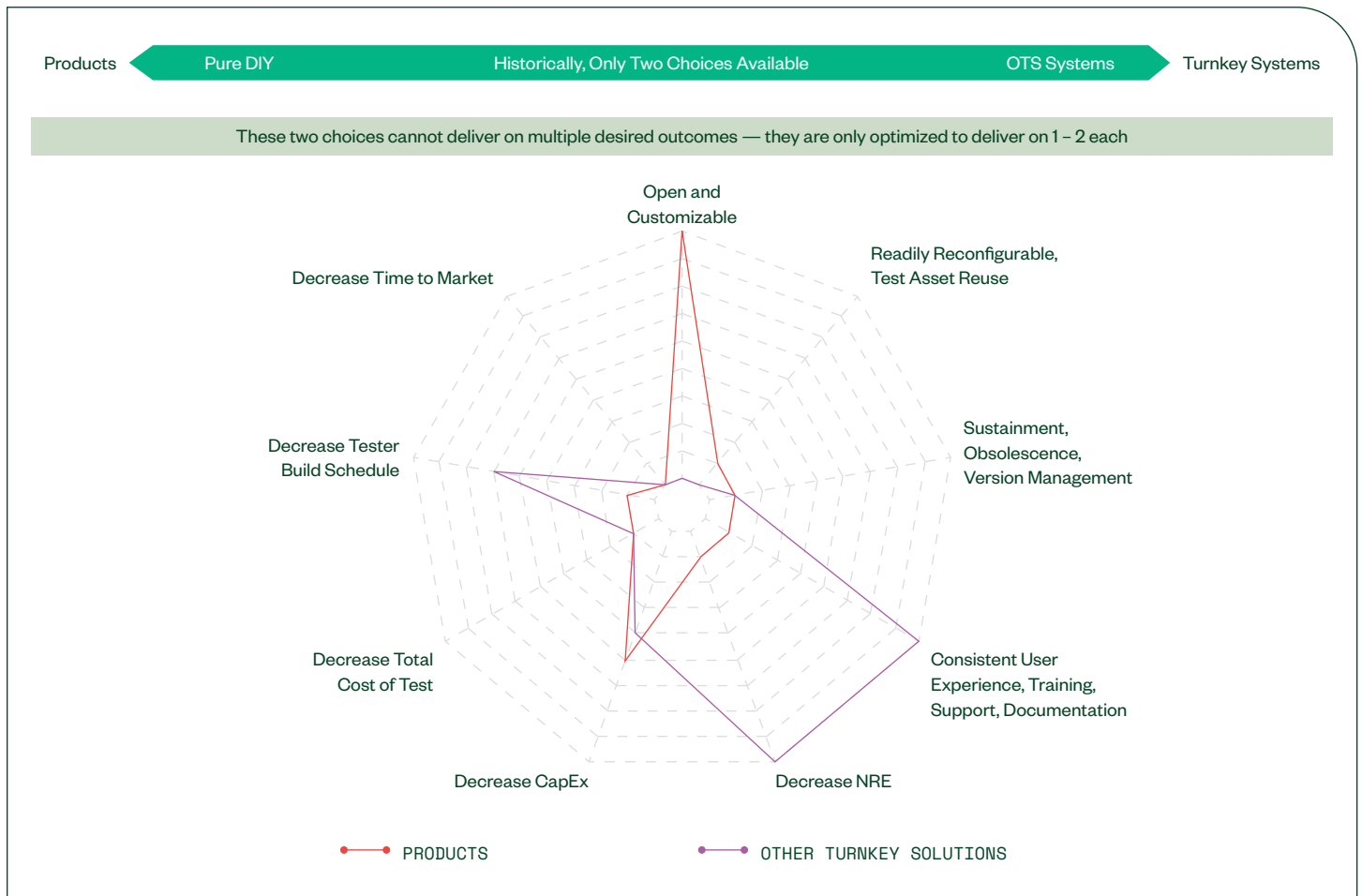

FIGURE 03
Historical Choices Limit Likelihood of Achieving Desired Outcomes

NI, through our Strategic Collaborations and joint investments with SET GmbH and Tech180, has developed an expanded set of choices that enable achievement of more desired outcomes. These choices are provided by a spectrum of delivery formats that can be customized to account for individual situations. Delivery formats can also be mixed and matched as required.

These expanded delivery formats are:

- NI LRU Test System Reference Architecture
- System-on-Demand Signal Path Implementation
- System-on-Demand System Build: This delivery format is highly customizable for specific needs. It may include a complete turnkey system, a partial system, design services, etc.

	ITEM	NI PARTS ORDER	PARTNER PARTS ORDER	NI REFERENCE ARCHITECTURE	SIGNAL PATH IMPLEMENTATION	SYSTEM BUILD
Documentation	BOM	Per Product Only		Per Signal Path		
	Reorderable Single Part Number					
	Product Documentation			Per Signal Path		
	Subsystem Assembly Documentation			Per Signal Path		
	Rack Assembly Documentation					
	Pintrace			Partial Per Signal Path		
	System User Manual					
Build	PXI Subsystem Build					
	SLSC Subsystem Build					
	Mass Interconnect Option					
	Power Subsystem Option					
	Custom Rack Components					
	Custom Build Delivery Format					
	UUT Harness					
	Rack Build					
Signals & Test	Partner Standard Signal Types			Limited Type Offering		
	Custom Signal Types			Limited Guidance Provided		
	Partner Standard System Test			Signal Path Specs Validated		
	Custom System Test					
	Self-Test					
	Integration Services					
SW	Linux RT Software	Drivers		Drivers and VeriStand		
	VeriStand System Definition					
	Custom Software					

Optional: Included:

TBL
1 | Comparison of Delivery Formats

System-on-Demand (SoD) is an innovative process and methodology that enables this approach to achieve more outcomes, as shown in Figure 4. System-on-Demand and the solution delivery formats:

- Use an open, standardized system architecture
- Are modular and reconfigurable
- Utilize little or no custom wiring
- Have complete, auto-generated system documentation
- Optionally include self-test
- Can evolve to multiple phases of the product life cycle

System Choices

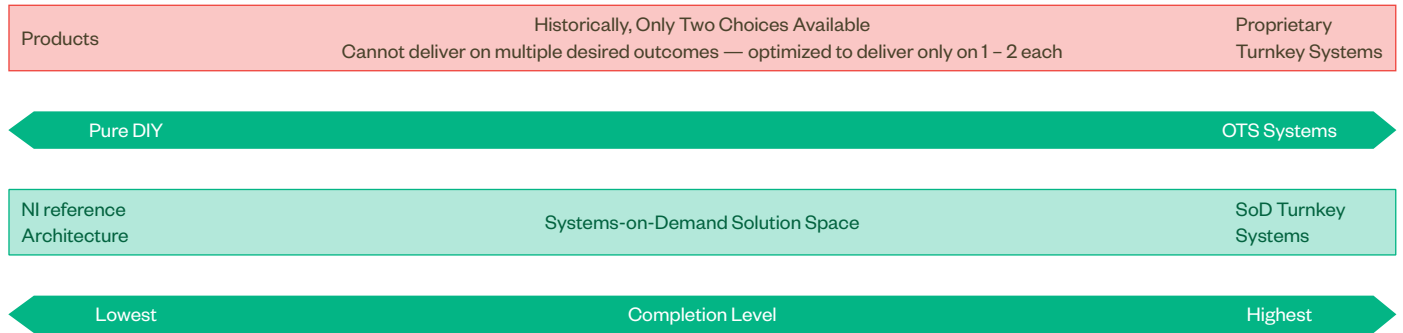

Impactful Outcomes

The NI, SET and Tech 180 approach enables you to have new choices to deliver on your priority outcomes based on your real-world constraints

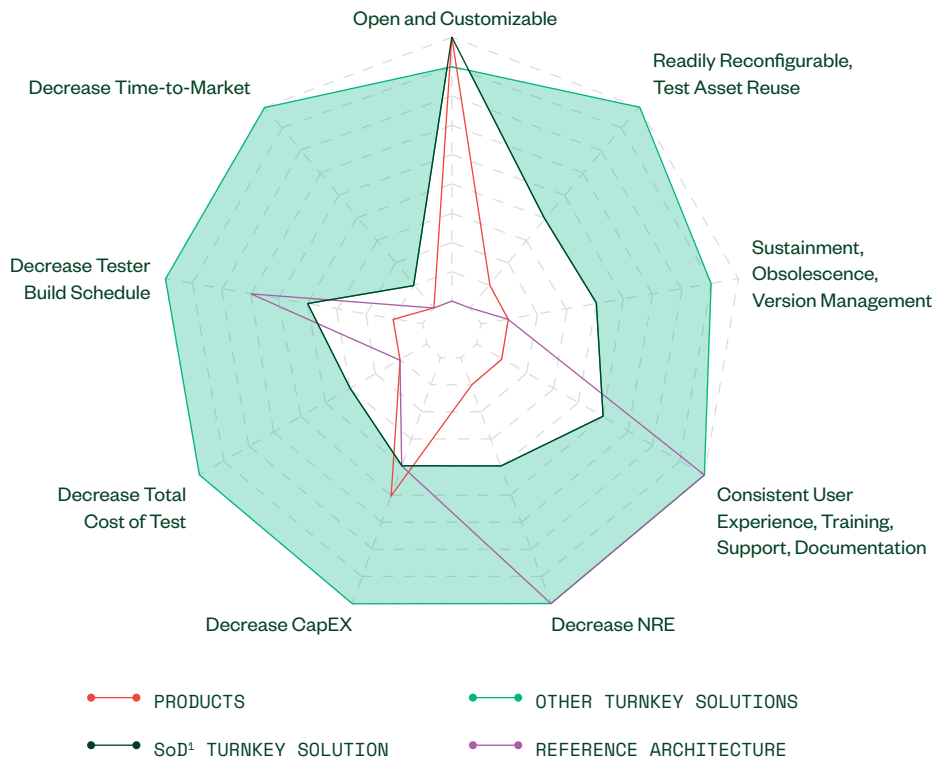

¹ SOD = SYSTEMS-ON-DEMAND FROM SET/TECH180

FIGURE 04
Comparison of Outcomes that Can Be Achieved

This is all accomplished through the System-on-Demand process and methodology which includes the synthesis of test systems from requirements. A simplified illustration of this process is shown in Figure 5.

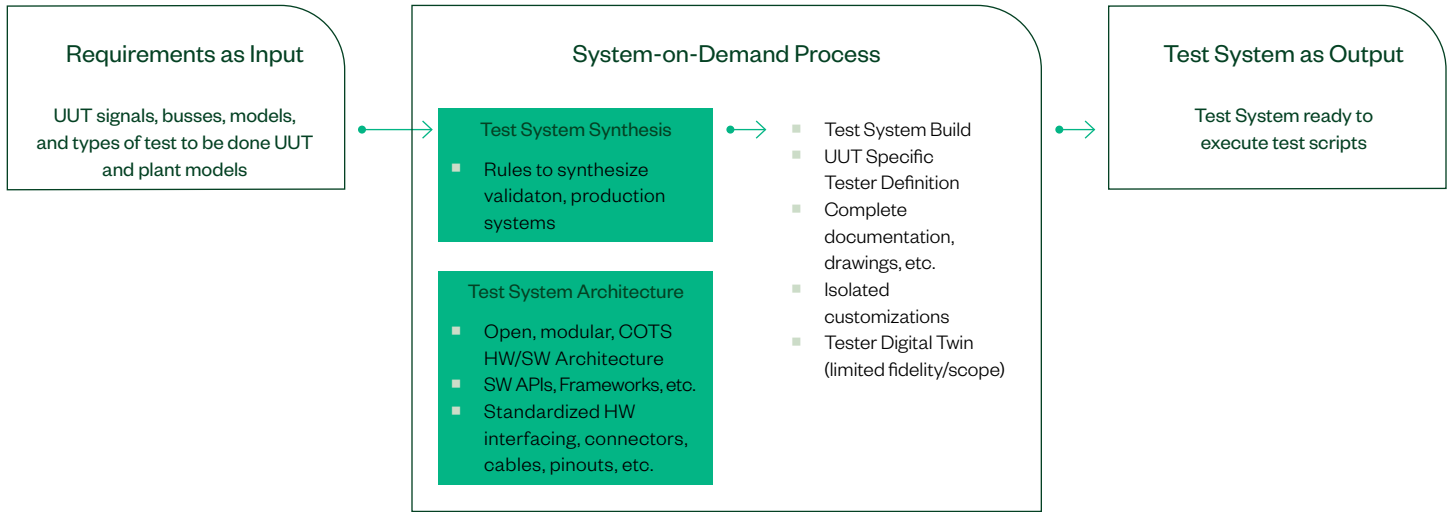
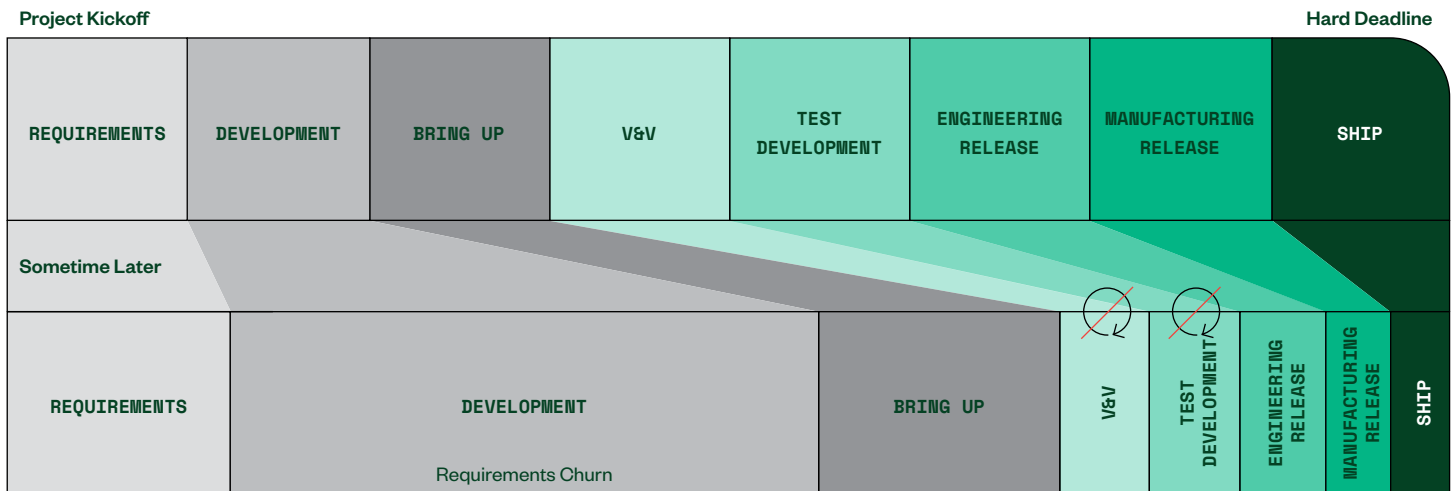

FIGURE 05
SET GmbH and Tech180 System-on-Demand Process

Each test system is consistent in design, in interfaces, and in the hardware and software used. This simplifies support, obsolescence management, training, and so forth across the globe. The speed at which test systems can be developed and the point at which test systems can be made available in the design and test process are key aspects to how this can enable more outcomes to be achieved while simultaneously reducing risk.

Figure 6 shows a simplified project timeline. Allotted times for test equipment and test development are often compressed due to the realities of the product design cycle. Heroic efforts have been made over the years by the test teams to optimize the development of test equipment and test procedures. There is simply not much room left for optimizations, yet these organizations are regularly asked to cut costs and schedules while meeting the testing requirements of increasingly complex UUTs.



= TRADITIONAL APPROACHES CAN'T OPTIMIZE ENOUGH TO MAKE A MEANINGFUL IMPACT

FIGURE 06
The Reality of a Program/Product Life Cycle

System-on-Demand enables a new picture to be created. As shown in Figure 7, test systems synthesized from requirements that are modular, reconfigurable, extensible, open, and customizable, de-risk the development of the test equipment. The tester design can be rapidly updated and new documentation provided in days. An interface model of the tester can also be provided, enabling test development to begin and proceed earlier in the design cycle. When the requirements finally settle, the physical tester can be delivered very rapidly.

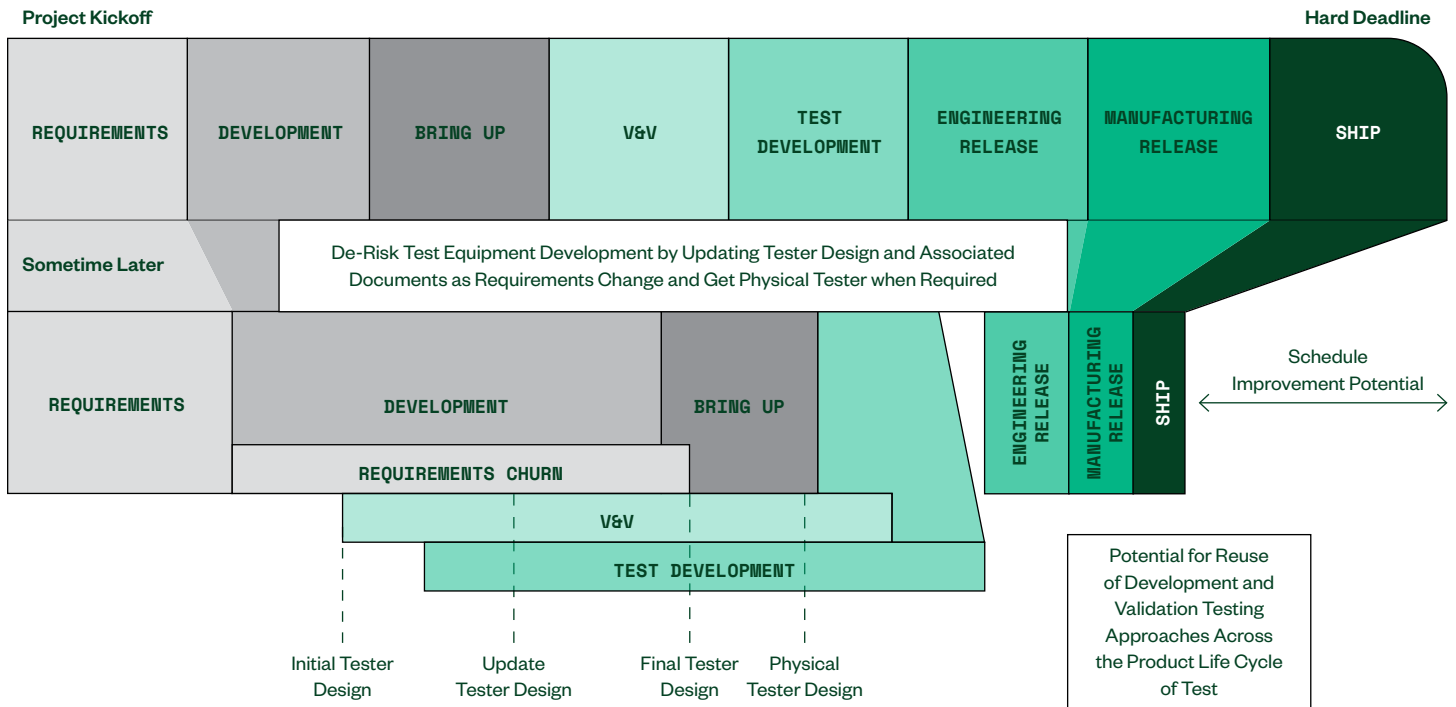

FIGURE 07
The Reality of a Program/Product Life Cycle

A “core system” is a system that can be built using purely off-the-shelf components and subsystems from the System-on-Demand catalog. Changes to the core system definition can be made as the product evolves. I/O or test capabilities and requirements that are not part of the catalog can be delayed and provided once the UUT design has been finalized.

This System-on-Demand process greatly reduces the risk that is inherent in creating test equipment for these complex UUTs/LRUs. The creation of the test equipment does not need to be delayed until the UUT is finalized.

To learn more about SET GmbH and Tech180, please refer to their specific sections in this brochure. Table 2 displays a matrix of what is included with each of the different solution delivery formats.

	ITEM	NI/TECH180/ SET PRODUCTS ¹	NI LRU TEST SYSTEM REFERENCE ARCHITECTURE ²	SET/TECH180 PLATFORM CONFIG. ³	SET/TECH180 CORE RACK DESIGN ⁴	SET/TECH180 CORE RACK BUILD ⁵	SET/TECH180 TURNKEY SOLUTION ⁶
Hardware	Rack Installation						
	PXI & SLCC Hardware						
	Interface Panels						
	Cables						
	Labeled Cables						
	Cable Harness						
	Custom Signal Types	Customer	Customer	Customer	Customer	Customer	
	MOTS						
	Hardware Sparing						
	Hard Drive Backup						
Software	VeriStand Configuration						
	TestStand Configuration						
	NI Software						
	Self-Test						
	Custom Extended Functionality						
Documentation	Signal Path Implementations with Specifications						
	Chassis Drawings						
	Cable Map						
	Rack Assembly Drawings						
	Pintrace						
	Electrical Schematics						
Support	SystemTag, Configuration Management						
	Additional Support Hours						
	NI Training						
	Customized Rack Training						
	Site Acceptance UUT Integration						

Optional: Included:

¹ NI/SET TECH180 PRODUCTS: COTS products purchased from NI and/or Tech180 and/or SET.

² NI LRU TEST SYSTEM REFERENCE ARCHITECTURE: Licensed NI Reference architecture that specifies a catalog of signal paths and their hardware and software implementations available as COTS products but does not provide a complete system or design.

³ SET/TECH180 PLATFORM CONFIG.: SET or Tech180 specifies and configures hardware and software foundational to test system requirements but does not design complete systems.

⁴ SET/TECH180 CORE RACK DESIGN: SET or Tech180 designs complete test system but does not perform final assembly tasks. Neither SET or Tech180 performs custom work.

⁵ SET/TECH180 CORE RACK BUILD: SET or Tech180 builds a complete test system but still performs no custom work. Full documentation is provided, and all types of support are available.

⁶ SET/TECH180 TURNKEY SOLUTION: SET or Tech180 builds a complete test system, including custom hardware and software where necessary. Full documentation and support are available.

Systems-on-Demand from SET GmbH

At SET, we're committed to ensuring our customers' success by integrating cutting-edge technology with tried-and-true best practices for test. As both a developer and manufacturer for flight-certified electronics and a specialist in aerospace electronics test systems, we bring a deep understanding of the full development process and the major challenges on both sides.

Given the scope of our expertise, we see a wide range of changes and major challenges, not only in new markets like urban air mobility but also throughout the entire aerospace industry, including:

- Shorter time to market
- Requirements identified too late
- Subsequent changes
- High risk to timeline, budget, and resources
- Accepting test system too close to deadline
- Obsolescence management
- Test systems that are not expandable

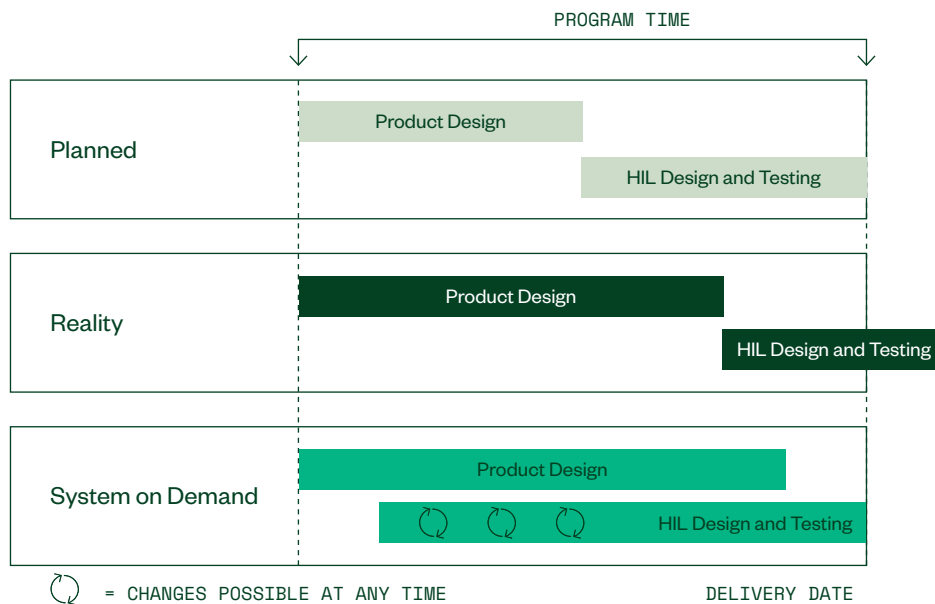

It's time to fundamentally change the way the aviation industry develops and tests products. That's why we've partnered with the best suppliers in the industry to invent System on Demand (SoD). SoD is an agile, standardized principle to design aerospace test solutions. It shifts the focus away from technical-only solutions to a proven automated design process that tackles our customers' real issues: **time, budget, and flexibility.**

Key Benefits of System on Demand

From ICD to Offer in 3 Days

It often takes a long time before all requirements of a test system are known. We generate the offer from your ICD. By including the signal specification in the offer already, risks up to the CDR can be eliminated before ordering! And you can easily add new requirements later.

HIL Test System in 12 Weeks

With SoD, we enable lead times of 12 to 15 weeks, so test systems are available in the shortest possible time. Plus, the entire design documentation and specification is available soon after the project starts. Our customers already receive the complete simulation environment for test implementation after finishing the design.

More Than 70 Predefined and Validated Signals

We've predeveloped and standardized more than 70 of the most common signal types as part of our architecture. This allows us to use pre-validated signals—removing any development and testing risk from your project. The pin trace is also known from the beginning.

Changes Are Possible at Any Time

Changes happen all the time in product development. But with us, you don't have to worry about them. If requirements are unknown at the beginning of the project or change later, we can quickly and easily incorporate them into our configuration. Thanks to our iterative design process, your timeline doesn't have to shift.



Transparent Budget and Reliable Timeline

Through the entire configuration in the offer phase, the system, its performance, and contents are clear from the beginning. We can give an exact delivery time directly with the offer.

COTS-Based Open Architecture

We rely on NI's proven and established hardware and software solutions. This ensures your obsolescence and spare parts availability and removes any development risks from the project. You can access the entire product portfolio at any time and adapt or expand it with the flexible architecture.

Reusable Test System Design

Until now, a new test system had to be purchased for each new UUT because they could usually not be reused. Now they can! Provide us with your new ICD, and we'll analyze the interfaces to be extended. We'll then send you the additionally required hardware and software or directly integrate it for you. This way, you secure your investment for future UUTs and significantly reduce the total cost of ownership in the actual and upcoming programs.

Product Ownership In-House

Only those who understand their test system are prepared to independently adapt their assets to rapidly changing market requirements. But in order to do that, companies had to elaborately develop aerospace test systems in-house—until now. With SoD, you can receive a complete overview of all signals in hardware and software, so the full test system knowhow stays in your company.

Complete System Integration

We not only support the development and validation of LRUs but also the subsequent qualification with customer-specific system integration rigs, providing for fast integration and test execution—as modular and open as our HILs.

About Us

Since its foundation in 2001, SET has been growing continuously and today employs more than 100 people at four locations in Germany and the United States. As a specialist in aerospace electronics test systems and as an aerospace development company, SET is EN9100 certified and delivers in series to European commercial aircraft.

Learn more at smart-e-tech.de/en/



Systems-on-Demand from Tech180

You're an innovator in aerospace products. We're innovators in aerospace testing. Together, we can solve the world's toughest challenges faster.

As flight-certified and similar products become more complex, the time necessary to meet test coverage requirements goes up as well. You'll need test systems sooner to keep your program on schedule and on budget, and the old ways of building test systems won't cut it anymore.

In an ideal world, your project timeline is front-loaded. You start with common pieces, integrate long-lead customizations, and then tackle test, fixes, and integration rework.

The Ideal Program

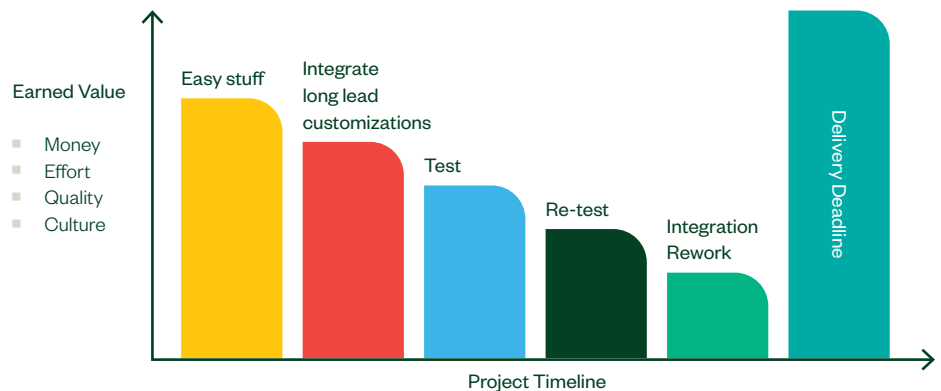

In reality, your labor and risk get pushed to the right. Delays in inputs and rework from requirements churn lead to a last-minute rush. Costs go up as deadlines loom.

The Real Program

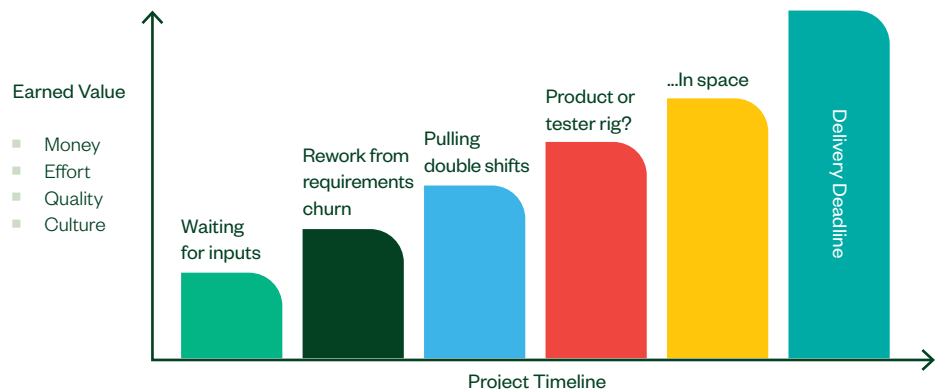

Tech180 Has the Answer

We're not just a systems integrator. We're your test partner, helping you turn testing into a competitive advantage. Our solution starts with agile development. Instead of waiting for your product to mature in order to start your test system design through a slow waterfall process, we can design, build, and validate portions of a test system requirement by requirement as your design matures. We can even synthesize test system requirements directly from product requirements so you can get the test system you need with a reduced statement of work.

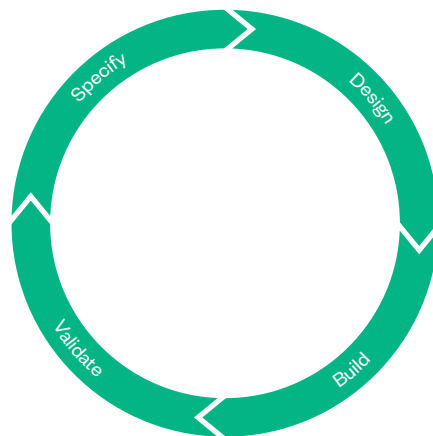

Tech180 produces systems with the most modular, open test architecture available. Our reconfigurable platform uses off-the-shelf hardware to drastically reduce the NRE necessary for custom product requirements. On-demand reconfiguration helps you meet the testing needs of multiple product lines, increasing hardware utilization and decreasing lifetime ownership cost.

While we certainly can provide test systems with off-the-shelf test executives, we can also support your legacy software workflows. Our I/O server approach with shared memory interface enables lab hardware upgrades without impacts on the existing software environment, so you don't have to choose between outdated hardware and endless software updates. We provide a single driver that uses generic physical layers to exchange data between hardware and software so your software won't even know it's talking to different hardware. This breaks the dependency of third-party hardware drivers on your software environment, reducing the maintenance and obsolescence challenges as hardware evolves.

We give you back time and money through systems available sooner with decreased NRE and less risk. All of this ensures that you get the test coverage you need, where and when you need it, so you can focus less on testing and more on what matters most: your product.

The future of flight is right around the corner, but the future of test has already arrived.

Tech180 Benefits in a Nutshell

- Agile development process reduces risk and delivers systems sooner
- Modular, reconfigurable platforms support multiple product lines
- Off-the-shelf components have all been tested together to decrease NRE
- Hardware abstraction layer preserves existing software environments

About Us

Tech180 is a fast-growing tech company that's advancing the future of aerospace engineering by creating the most modular test systems on the market. Our reconfigurable platform reduces the time and effort needed to translate product requirements into a test system specification, resulting in high-quality systems that are available sooner.

Move toward the ideal with Tech180 reconfigurable on-demand systems.

Learn more at tech180.us



NI LRU Test System (LRUTS) Reference Architecture

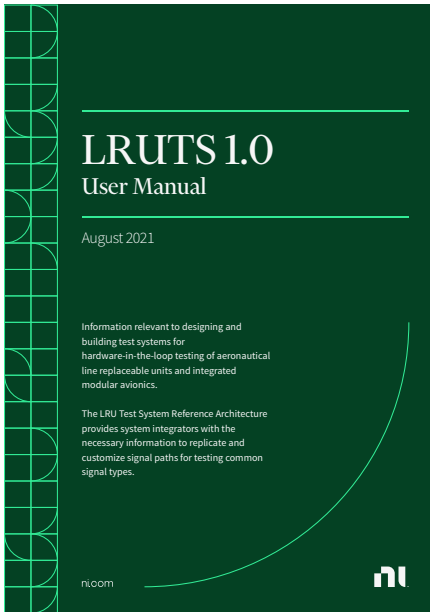

The NI LRU Test System Reference Architecture is a key enabling technology and product. The reference architecture is a set of core system components that have been designed, built, tested, and validated by NI to meet documented specifications. These system components are documented in the NI LRU Test System Reference Architecture User Manual. The reference architecture is a supported product from NI.

Some key aspects of the Reference Architecture are its standardized and modular connectivity scheme including pinouts, signal banking, standardized connectors, and cables. The connectivity scheme is a primary attribute of enabling a modular, scalable, extensible architecture.

The User Manual documents the signal types and communication interfaces that are supported, the theory of operation, the connections, the bill-of-materials, the specifications, and the supporting software amongst other required information. Customization of the signal path, including fault insertion, new capabilities using FPGAs, etc., is also described.

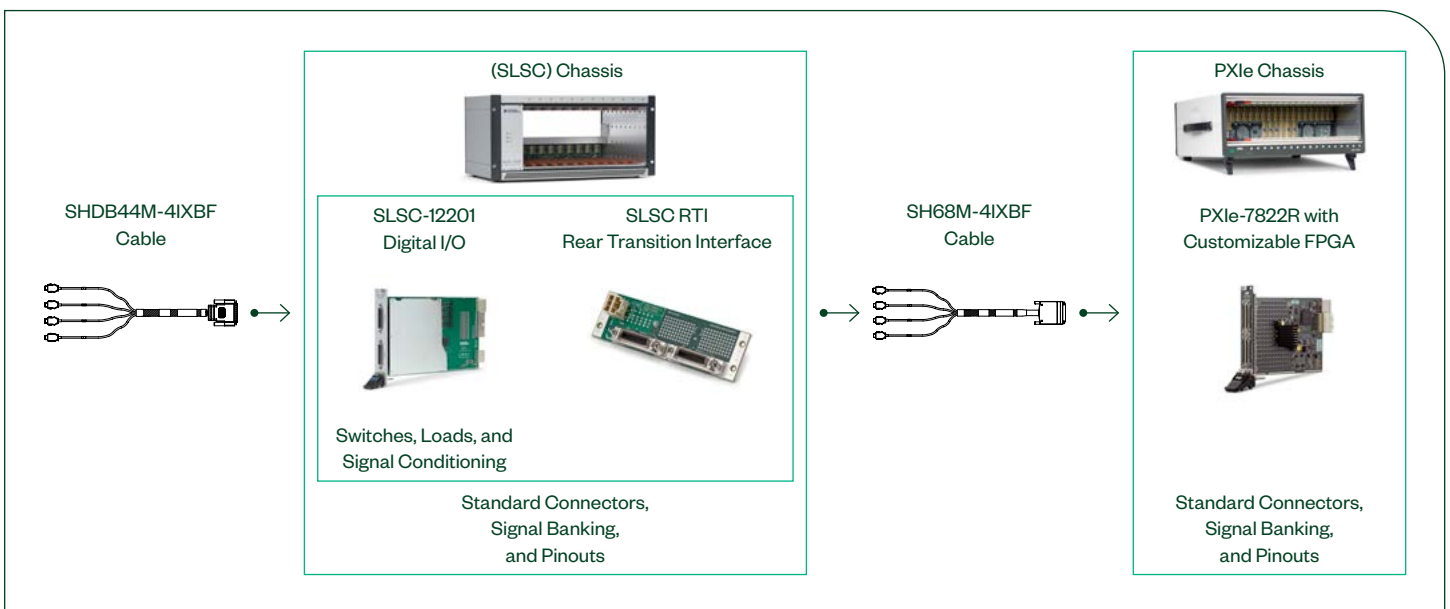

FIGURE 08
Example Digital I/O Signal Path

The User Manual provides you with what you need to begin designing and building LRU test systems using the modular, standardized, open architecture that is also part of the Systems-on-Demand solution delivery formats.

Specifications

Refer to the following specifications for key characteristics of the discrete acquisition signal path.

Note The following specifications apply to a single implementation of the discrete acquisition signal path. Making any customizations to the signal path may change these specifications.

Number of banks	8 per PXIe-782x DIO connector
Number of signals per bank	4
Signal type	Differential
Voltage range	0 V to 5 V 0 V to 33 V
Input configurations	Sourcing Sinking
Sourcing pull-up resistor	24 k Ω
Maximum signal frequency	100 kHz
SLSC-12201 Specifications (5 V range)	
Hysteresis	0.7 V
Input threshold setting range	0.74 V to 4.2 V
Input threshold setting resolution	4.4 mV
Input impedance (sinking input)	200 k Ω
SLSC-12201 Specifications (33 V range)	
Hysteresis	3.7 V
Input threshold setting range	4 V to 27.5 V
Input threshold setting resolution	23.3 mV
Input impedance (sinking input)	110.4 k Ω

Figure 39. Discrete Acquisition Signal Path Hardware Connections

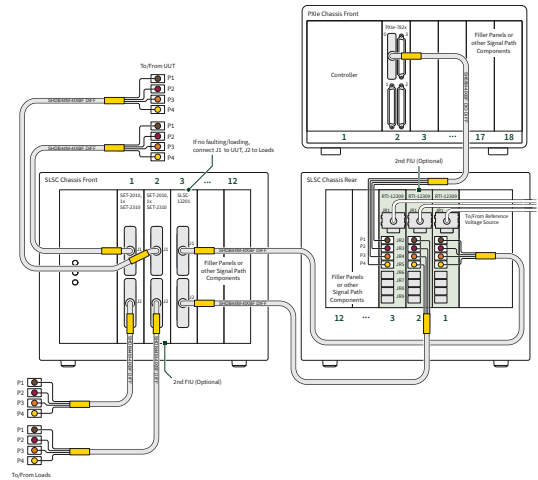

FIGURE 09

Example Specifications and Diagrams

LRU HIL Run-Time System-Level Architecture

NI has purpose-built these modular components so they come together to form the signal-flow portion of an HIL system. This modularity supports a more agile approach to the systems design, modification, and sustainment of these complex test systems.

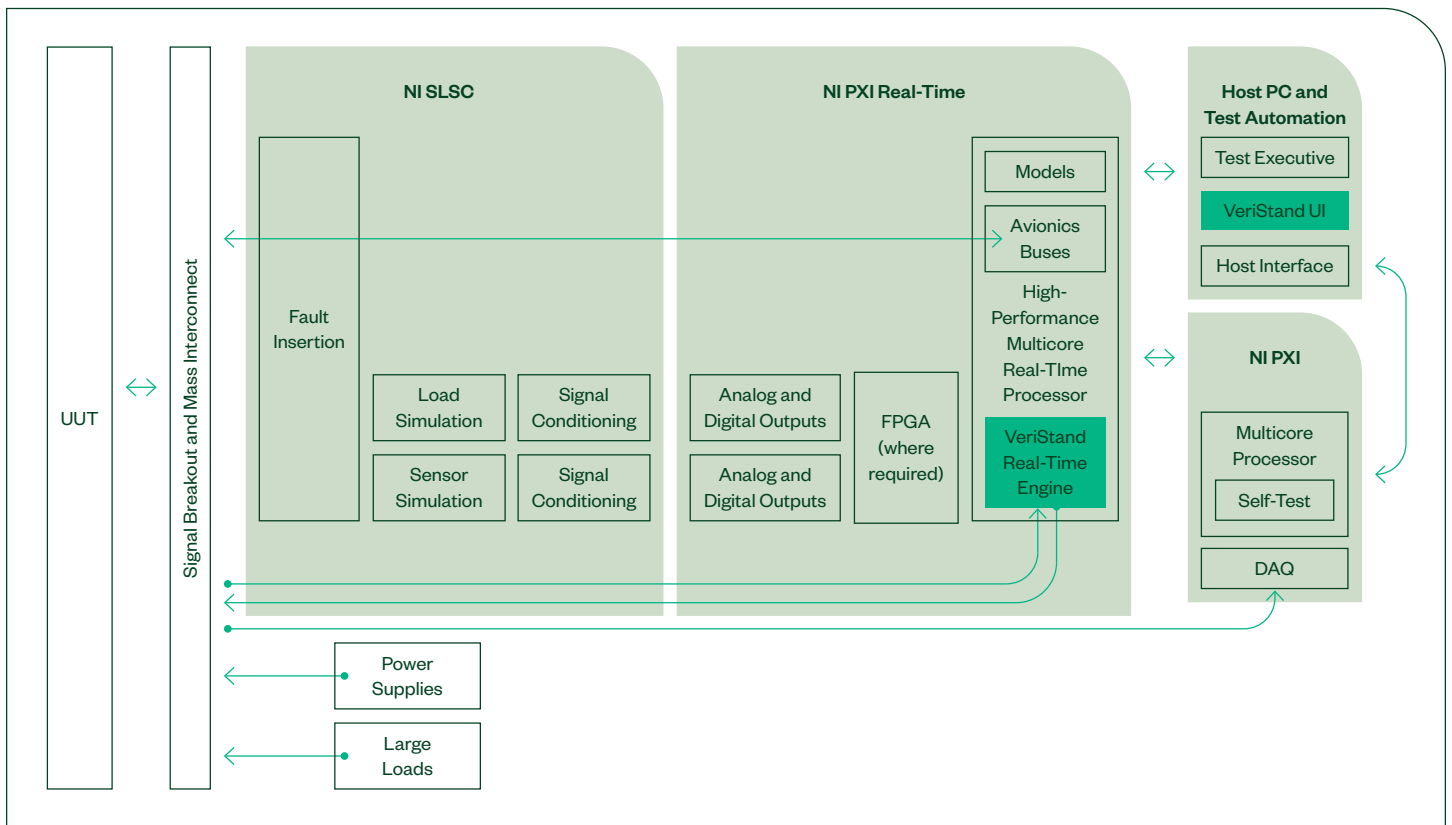

FIGURE 10
Signal-Flow Architecture of a Modular and Flexible HIL Test System

LRU HIL System Software

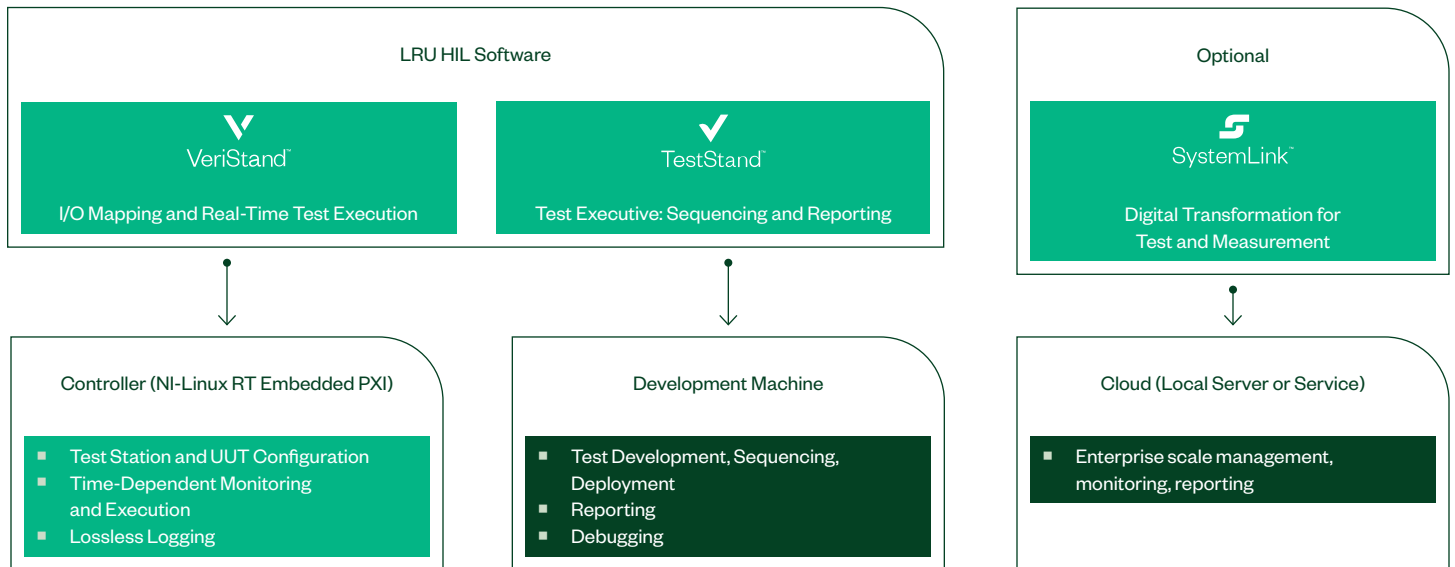

FIGURE 11
NI Application Software for HIL Test Systems

Real-Time Test Software and Model Integration—VeriStand

VeriStand is an application software environment for configuring and executing real-time test and HIL applications. It can help you construct a multicore-ready real-time engine to execute tasks such as real-time stimulus generation, data acquisition for high-speed and conditioned measurements, calculated channels, and custom channel scaling—out of the box. VeriStand runs on NI's industry standard Linux RT.



VeriStand can also import control algorithms, simulation models, and other tasks from both LabVIEW and third-party environments. VeriStand supports MathWorks® Simulink® software and other modeling tools using the FMI industry standard. You can monitor and interact with these tasks using a run-time editable user interface that includes tools for value forcing, alarm monitoring, I/O calibration, and stimulus profile editing. You can customize and extend VeriStand with a variety of software environments such as LabVIEW, ANSI C/C++, ASAM XIL, and others for modeling and programming.

VeriStand is architected to have a real-time engine that runs independently from the user interface to ensure the determinism of the system you're running. You can use VeriStand to interface with another compute environment and application software using shared memory to preserve any needed compatibility unique to your requirements.

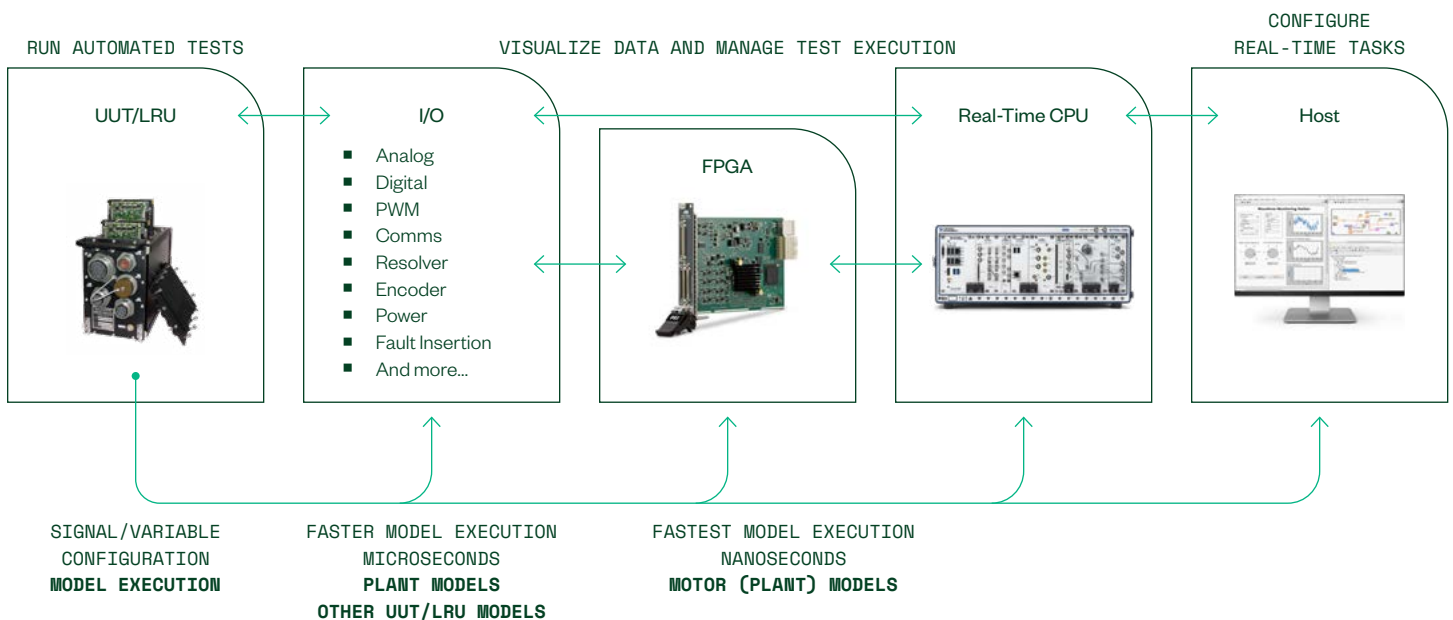

* LRU IMAGE COURTESY OF CURTISS-WRIGHT DEFENSE SOLUTIONS

FIGURE 12

VeriStand Coordinates and Deploys Models across Different Processors

Test Sequencing and Test Management Executive Software—TestStand

TestStand is ready-to-run test management software designed to help you quickly develop and execute transaction processing system (TPS) software. You can extend TPS functionality by developing TestStand test sequences that integrate code modules written in a variety of programming languages, including G in LabVIEW, C/C++, .NET, and Python. TestStand also provides extensible plug-ins for reporting, database logging, and connectivity to other enterprise systems. You can deploy test systems to production with easy-to-use operator interfaces.

Additionally, you can use the TestStand Tool Qualification solutions from Genuen to assist in achieving DO-178C test qualifications, saving time and money on each program.

KEY BENEFITS

- Customize test sequences to meet every requirement
- Automate saving and reporting test data
- Increase test throughput with parallel testing
- Efficiently replicate and deploy test systems
- Troubleshoot test systems with integrated debugging tools
- Customize user interfaces to meet testing needs

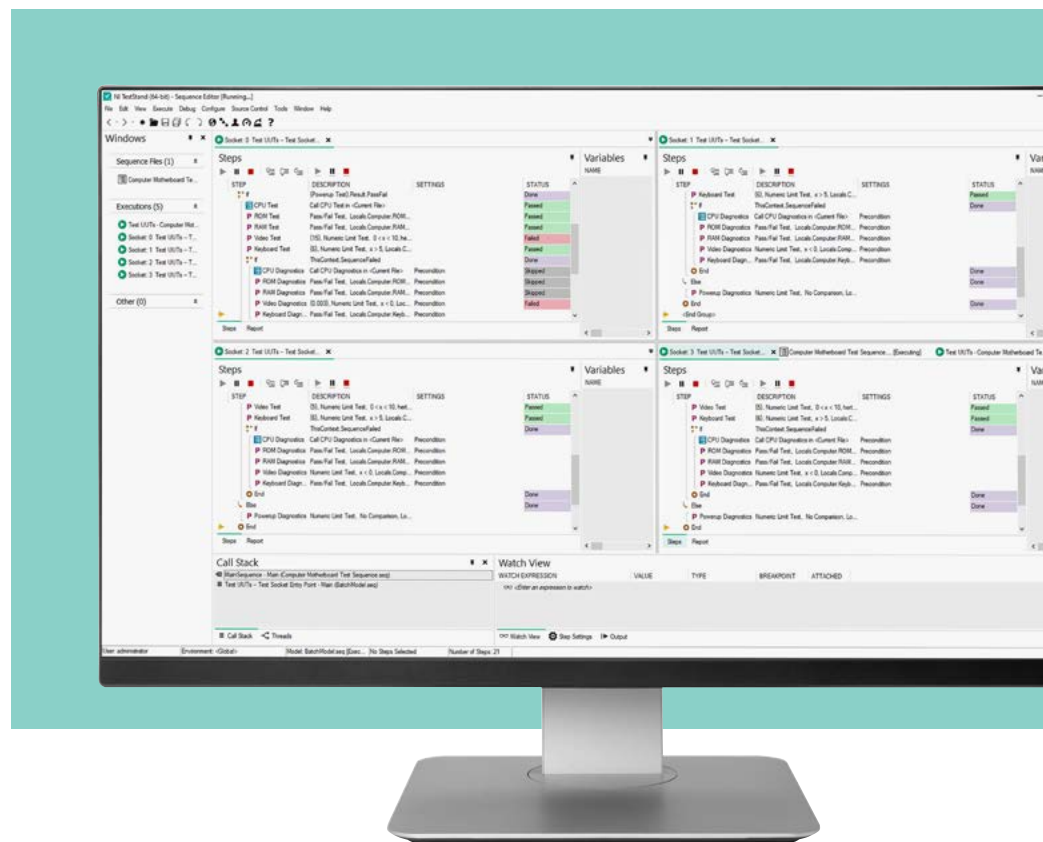

LRU HIL System Hardware Components and I/O

An LRU HIL test system is complex and built from a large number of electrical, mechanical, and interconnect components.

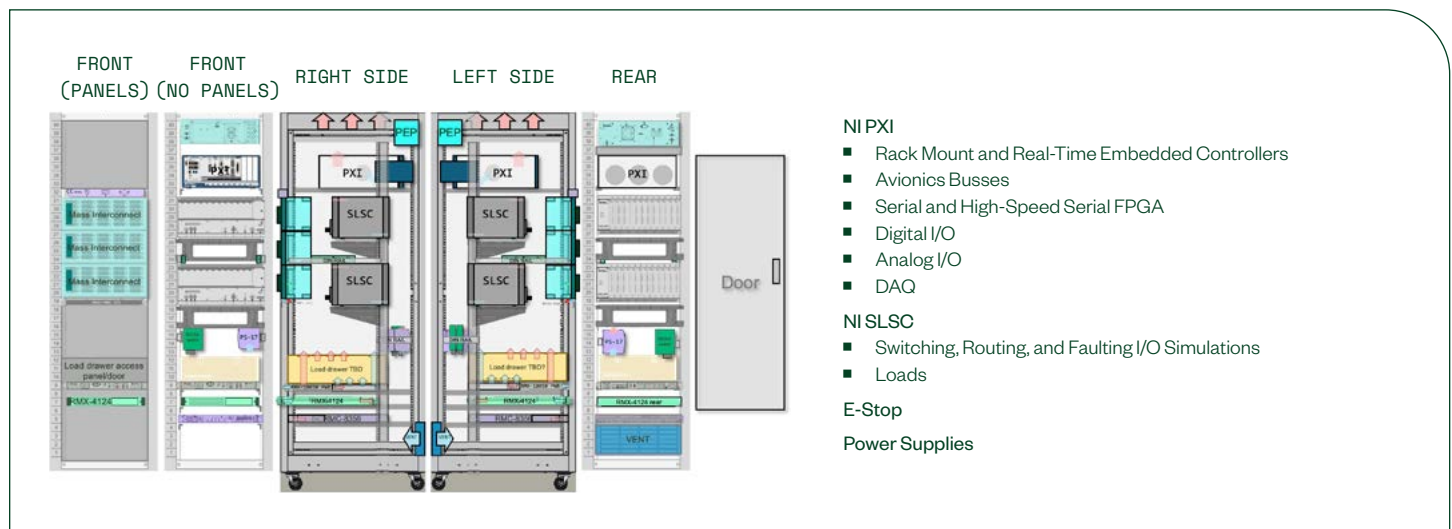

Image courtesy of Curtiss-Wright Defense Solutions

FIGURE 13
Conceptual LRU HIL Test Rack

Acquire, Process, and Interpret Data—NI PXI/PXI Express

PXI is a PC-based industrialized system that combines PCI Express electrical-bus features, a modular chassis, and I/O synchronization technology with user-defined or application-specific test software. PXI is an open industry standard governed by the PXI Systems Alliance, a group of more than 70 global test companies. NI was one of the pioneer companies in the formation of PXI and is recognized as a leader in PXI test and measurement devices.

Instrumentation available in PXI/PXI Express form factor includes:

- Analog and digital I/O
- Digital multimeter
- Oscilloscope/digitizer
- Waveform generator
- Switch and timing/synchronization
- Source measure unit (SMU)
- Programmable DC power supply
- Electronic load
- Instrument control and synchronization
- FPGA processing board

Real-Time, Embedded, and Rack-Mount Controllers

PXI Express embedded controllers contain everything you need to run your PXI system without an external PC. They typically run a real-time operating system, such as NI's industry standard Linux RT while rack-mount controllers run the user interface and host operating system.



FIGURE 14
Range of PXI Express Controllers and Chassis to Meet Your Needs

Rack-mount controllers feature high-performance multicore processors, up to 32 GB of dual-channel DDR2 RAM, and optional RAID hard drive configurations for high-speed streaming to disk. These devices offer hot-swappable fans and options for redundant power supplies. These rack-mount controllers for PXI are designed for mission-critical, physically demanding applications.



FIGURE 15
Range of Rack-Mount Controllers

PXI/PXI Express Instrumentation, Buses, Communications, and FPGAs

NI offers more than 600 [PXI modules](#), ranging from DC to mmWave. Because PXI is an open industry standard, nearly 1,500 products are available from more than 70 different instrument vendors. With standard processing and control functions designated to a controller, PXI instruments need only contain the actual instrumentation circuitry, achieving effective performance in a small footprint.



Avionics Buses

Avionics Communication Bus modules provide native support for protocols such as MIL-STD-1553 and ARINC 429. Use these products to simulate and enable communication with your UUT.



Serial and High-Speed Serial

Use for other standards or custom serial communication protocols.



FPGA

Provide high-performance I/O and powerful FPGAs for applications that require more than standard instruments can offer. Program with LabVIEW FPGA or Xilinx Vivado. Run model simulations and perform in-line data processing.



Digital I/O

Read and write switch states and binary logic. Detect open and closed states. Interpret CMOS TTL logic levels up to 28 V logic signals. Track counter-based or encoder measurements.



Analog I/O

Interpret instrument level conditioned sensor measurements. Read and write the voltage levels for sensors. Analyze pressure and position measurements.



Data Acquisition

Data Acquisition modules measure electrical or physical phenomena with a mix of analog I/O, digital I/O, counter/timer, and trigger functionality.

Transform Signals—NI SLSC

Switch Load and Signal Conditioning, or [SLSC](#), is a key aspect to the NIL LRU HIL product family. SLSC standardizes connectivity and provides a modular approach to signal conditioning, fault insertion, routing, and I/O simulation that typically require more power or space for circuitry than allowed by the PXI standard. The SLSC platform includes standardized interfaces and connectivity to modularize and simplify the complexity of HIL systems. This eliminates most point-to-point wiring and terminal block usage. A module development kit (MDK) is also available for defining custom SLSC modules.



Switching, Routing, and Faulting

Designate signal connections and path possibilities:

- Switching—determine which path is active
- Faulting—route to fault sinks or endpoints



I/O Simulations

Replicate the electrical component behavior of complex sensor signals. Simulate sensors like VDT or thermocouples, resistors, and more. Custom capabilities like PWMs can be readily implemented on the FPGA using LabVIEW FPGA.

Loads

Manage small loads on a single card. Combine with SLSC routing cards to reach higher level loads. Simulate power draws from simulated resistive and RLC circuits.

Ecosystem SLSC Modules and Accessories

A variety of SLSC modules and accessories are also available from:

- [SET](#)
- [Bloomy](#)

Programmable Power-Supply Devices

Built for automated test, [rack-mount power supplies](#) provide programmable DC power in either full or 1/6 rack-width, rack-mount form factors. The RMX-412x models offer up to 1,500 watts of power in a 1U, full-rack form factor with flexible voltage and current limits ranging up to 650 VDC or 150 A, making them ideal for test systems that require large amounts of power with a broad range of voltage and current values. For applications requiring more than the specified voltage or current limits, you can combine up to two devices in a series for higher voltage and up to four devices in parallel for higher current. The RMX-410x models can source hundreds of watts in a compact 2U, 1/6 rack-width design, ideal for test systems that need multiple power rails. Additionally, both series offer buttons and knobs for interactive use, as well as USB, LAN, RS232, and analog control options for remote or automated use.



- **SOFTWARE:** API support for LabVIEW with shipping examples: SCPI-compliant for use with NI-VISA and text-based languages
- Up to 1,500 W options
- Output up to 650 V or 150 A, depending on model
- Combine multiple devices for higher voltage/current
- Calibration software utility included

Electronic Load Devices

Built for automated test and measurement, [Electronic Load Devices](#) can sink power at various current and voltage levels for power supply design, quality inspection, and functional tests. Their modular design and multiple operating modes help them simulate the real load that a power source sees in its actual application. They also feature buttons and knobs for interactive use, as well as USB or RS232 interface options for automation. You can connect multiple loads in parallel to increase your system's overall power capacity.



- **SOFTWARE:** API support for LabVIEW with shipping examples: SCPI-compliant for use with NI-VISA and text-based languages
- One- and two-channel options
- Sink up to 350 W
- Up to 500 V
- Up to 70 A
- Stack multiple channels and link multiple mainframes for higher power and parallel operation

Services and Support

NI provides several services and support options to help ensure your short-term and longer-term success with our products. We've partnered with many aerospace and defense companies to provide extended, long life-cycle support that can span decades.

	BASIC	CUSTOM
Software Support Access to updates and bug fixes	Access to Software Updates	Scope is defined with customer on a case-by-case basis
Repair and Replacement Minimize downtime	3 - 5 Days Replacement	
Technical Support Resolve issues quickly	Technical Support 8x5	
Field and Remote Services Fixed maintenance cost		
Life-Cycle Management Mitigate obsolescence risk	Standard Product Notifications	
On-Demand Training Ensure user success	Online Operator Maintenance Training	

	OPTIONS
Calibration Quality measurements and traceability	Laboratory Calibration On-Site Calibration Calibration Replacement
Bring-Up Assistance Hassle-free commissioning	On-Site or Remote Tester Bring-Up
Training Ensure user success	Private Classroom (On-Site or Virtual) for Operator and Maintenance Training
Professional Services	Integration Services, Technology Refresh, and Upgrade Assistance Consulting Services Resident Engineer

LRUTS Reference Architecture Partner Ecosystem

We work closely with our uniquely qualified partners so that our customers see the greatest return on investment from their HIL test systems. Bloomy is a high-value partner who provides great solutions, especially for those with highly custom needs. Bloomy is well versed in NI products and the NI LRU Test System Reference Architecture.



On-Demand ExpertiseSM

Bloomy

You know that deploying a LRU validation system is much more than buying a rack of equipment. It's designing before requirements are complete and incorporating changes after the design is done. It's controlling program risk while using untried test solutions. It's using yesterday's technologies to create the systems of tomorrow. It's solving a myriad of challenges every day.

During Bloomy's 30+ years of experience delivering highly complex COTS-based test systems for mission-critical programs, we've developed a deep understanding of these challenges, and we've solved them by creating an extensive portfolio of efficient processes and highly integrated solutions. Our expertise allows us to partner with customers to leverage the breadth of our experience, resolving each unique challenge. In fact, NI tapped Bloomy to codevelop SLSC and provide the first LRU validation systems using this transformative new technology. With each system we deploy, whether it's a simple single-unit validation system or a complex SIL with thousands of channels, high-performance digital buses and high-fidelity models, we help our customers reduce risk, schedule, and cost.

Learn how we can partner to improve your test system experience, too! Visit bloomy.com today.



Scalable COTS Solutions

Our solutions range from single UUT systems to multi-UUT SILs, and our 80 percent application-ready solutions dramatically reduce system lead times and costs.



Engage at Any Stage

We can add value to any point in your verification and validation process, whether supplying only a test system or working with you from concept through certification.



Complete Life Cycle Solutions

Bloomy's comprehensive life-cycle support services include requirements development through Total Productive Maintenance and obsolescence management.



Simulation Systems Expertise

NI and Primes utilize Bloomy's expertise and HIL Technology Migration Lab, a Bloomy system available to our customers, to reduce upgrade cycle risk.



Project Management Your Way

Bloomy's experience with many types of project and program management, from agile to waterfall, allows us to engage with your team faster, with less risk.



A Deep Bench of HIL Experts

As a company focused solely on test solutions, we've amassed extensive resources, capabilities, and IP, enabling us to take on your most demanding HIL projects.



US Owned and Operated

As a fully US owned and operated company, we conform to strict standards of defense and cybersecurity requirements.



30+ Years of Excellence

Our 30+ year track record of outstanding service shows that we're able to support long lifespan, multidecade programs.



Large-Scale Capacity

With extensive production and integration facilities, Bloomy is equipped to handle your largest multi-UUT development programs.

Expertise for All Phases of the Test System Life Cycle

The traditional test organization “does it all,” developing highly specialized test equipment and developing product test engineering expertise. But since Bloomy introduced our mil/aero HIL architecture using the SLSC platform, test organizations of all sizes have another option: focus their test engineers on improving fidelity, coverage, and reliability of their products while using Bloomy's expertise to enhance the process of deploying test systems. Bloomy provides systems expertise—everything from codeveloping requirements to deployment and life-cycle management—for all your HIL needs.

Your IP Deserves Defense-Grade Protection

Your IP differentiates you from your competitors and deserves the same careful handling that the DoD requires. Defense, Prime, and Tier 1 organizations all count on Bloomy to provide automated test solutions, and as the mil-aero industrial complex continually increases its attention on security, so do we. We have invested heavily in CMMC Level 3, ITAR, and NOFORN, and have expansive ITAR-compliant integration and lab space dedicated to supporting proprietary UUTs and systems to the benefit of both military and commercial customers.

Solutions for Systems of All Sizes

Whether you're testing one LRU, or building a SIL or an iron bird, Bloomy delivers high-fidelity solutions which ensure full coverage of your requirements. Our proven solutions for flight controls, avionics, engine controls, autonomous submarines, and other mission-critical controls have been used in systems of all sizes and complexities. Our expertise developing highly complex COTS HIL systems is unparalleled, so you can be sure that Bloomy will meet your system needs of any size or complexity.

Real-World Results

Bloomy's systems have reduced test times by 30 percent over legacy automated test solutions. When Bloomy delivers a test system to a customer, we provide the documentation, designs, and software code, no matter the customer or application. Whereas other companies lock you into using their services for any change, large or small, Bloomy frees you to update, examine, modify, and self-maintain your systems. And because the software is a widely supported COTS toolchain with LabVIEW at its core, the learning curve is dramatically eased. As a result, change is in your power.

Your System, Your IP

Learn more at bloomy.com





For Additional Information

NI Aerospace and Defense Exchange Forum Webcasts

- [We Got Tired of Reinventing the Wheel—So Now We Build SILs Using COTS Technologies! Find Out How!](#)

Customer and Partner Success Stories

- [Embraer Performs Full Airplane Simulation Using NI HIL Tools](#)
- [Saab Elevates Testing of the World's Most Cost-Effective Fighter Plane](#)

From Our Partners

- [SET Video Series Aviation & System On Demand \(German\) \(English\)](#)
- [Tech180: Test System Architecture Video Series](#)
- [Bloomy: white papers, case studies, presentations, and videos](#)

NI offers a variety of service options including system design support. Work with our team to properly integrate NI's architecture with third-party components to maximize the performance and reliability of your Launch Operations systems.

Additionally, NI service teams are available to provide hardware services and calibration, on-site system calibration, installation verification to ensure the NI content is properly installed and configured in your system, and in-person or online training for NI software.

Contact your account manager or call or email us to learn more about how NI can help you reduce the design, deployment, and commissioning times in your next Launch Operations system at (888) 280-7645 or info@ni.com.

ni.com
ni.com/lruts



©2022 NATIONAL INSTRUMENTS. ALL RIGHTS RESERVED. NATIONAL INSTRUMENTS, NI, NI.COM, LABVIEW, SYSTEMLINK, TESTSTAND, AND VERISTAND ARE TRADEMARKS OF NATIONAL INSTRUMENTS CORPORATION. SIMULINK IS A REGISTERED TRADEMARK OF THE MATHWORKS, INC. OTHER PRODUCT AND COMPANY NAMES LISTED ARE TRADEMARKS OR TRADE NAMES OF THEIR RESPECTIVE COMPANIES.

AN NI PARTNER IS A BUSINESS ENTITY INDEPENDENT FROM NI AND HAS NO AGENCY OR JOINT-VENTURE RELATIONSHIP AND DOES NOT FORM PART OF ANY BUSINESS ASSOCIATIONS WITH NI. 88026